

COMPACT RANGE

SPL Series

Patent Pending

VACUWORX®

The Solar Panel Lifter system allows easy installation and manipulation of solar panel modules in field via attachment to a variety of mini-excavators. This system reduces worker fatigue and wind gust concerns, increases worker safety, and gently handles the delicate modules.

- 360° rotation of pads for panel alignment.
- 5 inches of vertical vacuum pad travel to protect panel if misaligned.
- Folding legs for storage.
- Alignment tips to keep cups parallel to panel during attachment.
- 12V system powered from the excavator's charging system.
- Captured ball joint vacuum pad connections.
- Soft silicone vacuum pads prevent damage to panel.
- Quick Change adapters available for various host equipment.
- 300 lbs standard capacity.



Specifications

	Lift Capacity (kg)	Weight (kg)	LxWxH (mm)
Lifter	300 lb (136 kg)	120 lb (54.4 kg)	32.1" x 30.1" x 46.3" (815.3 x 764.5 x 1,176 mm)

Quick Hitch Adapter to fit client's host equipment (weight not included).



Pallet Curler and Swivel Trailer

Patent Pending

The Pallet Curler and Swivel Trailer system allows easy rotation and movement of solar panel pallets in field. The Pallet Curler attaches to skid steers to freely operate and move pallets while the SPL is attached to a separate host machine. The Swivel Trailer, which attaches to mini excavators and is equipped with wheels, ensures that both the Swivel Trailer and SPL remain on the same host machine, reducing the amount of machinery required in the field.

- 90° rotation of pallets allows for ideal horizontal position during installation.
- Runs on the hydraulic power take-off of host machine.
- Controlled by host machine's controllers.
- Safety Bumper protects panels when moving and rotating.
- Allows for easy movement, rotation, or relocation of the solar panel pallet, minimizing worker fatigue and injury.

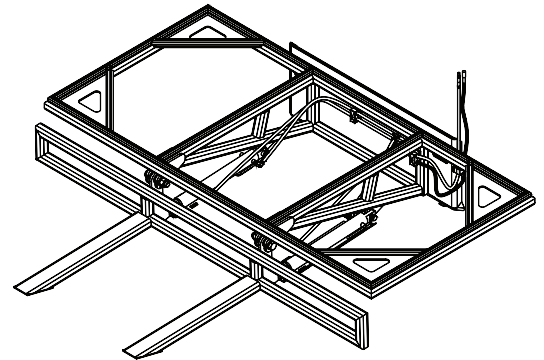

Specifications

	Lift Capacity (kg)	Weight (kg)	LxWxH (mm)
Trailer with Wheels	3000 lb (1,360.7 kg)	912 lb (413.7 kg)	124" x 109.8" x 50" (3,149.6 x 2,789 x 1,270 mm)
Curler without Wheels	3000 lb (1,360.7 kg)	580 lb (263 kg)	90" x 51.2" x 50" (2,286 x 1,300.4 x 1,270 mm)

